

www.rotofluidpumps.com  
All Stainless Steel  
ROTARY TWIN GEAR PUMPS

Series : FTMS



Rotary Gear Pumps  
SINCE : 1993

**Perfect Solution**  
for Transfer of Corrosive, Hygienic  
& Viscous Liquid

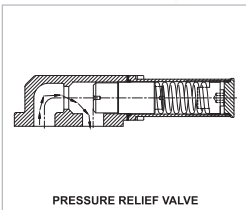
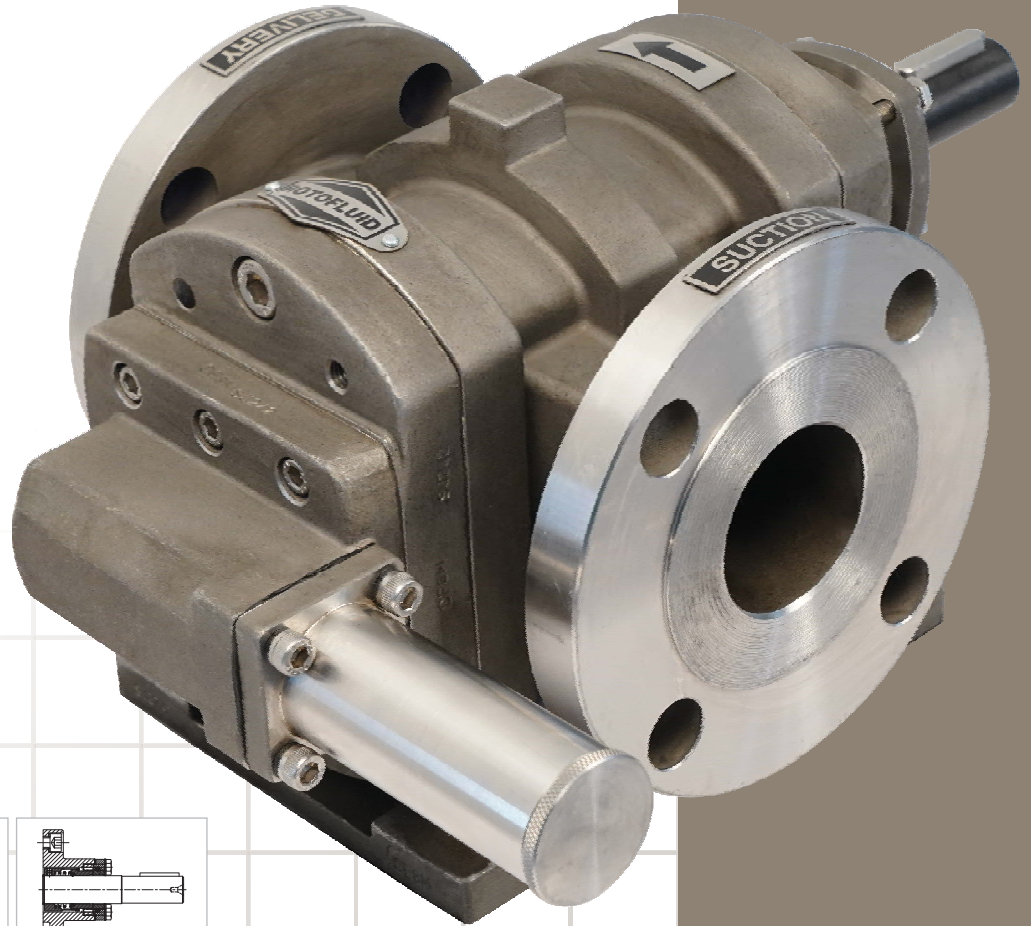

PRESSURE RELIEF VALVE

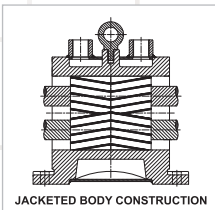

JACKETED BODY CONSTRUCTION

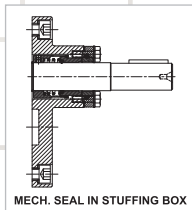

MECH. SEAL IN STUFFING BOX



An ISO 9001:2015 Certified Company

**Fluid Tech Systems**

Ahmedabad - 382 430. (Guj.) INDIA



ISO 9001 : 2008



TUV NORD GROUP

*“Let Our  
Quality Speak  
For Itself”*

**ROTOFLUID®** brand Rotary Twin External Gear Pump Model FTMS – heavy duty foot mounting type positive displacement rotary pump. FTMS is all stainless steel (SS-316) with flange (class 150#ASME/ANSI B16.5)

## MODEL & PERFORMANCE CHART

PUMP MODEL (SUCTION & DELIVERY)		CAPACITY			RECOMMENDED MOTOR BHP AT 1440 R.P.M.		
		LPM	US GPM	M <sup>3</sup> /hr	Up to 3 kg./cm <sup>2</sup>	Up to 7 kg./cm <sup>2</sup>	Up to 10 kg./cm <sup>2</sup>
FTMS - 50 ½" X ½"	S	15	3.9	0.9	0.5	0.75	1.0
	M	20	5.2	1.2			
FTMS - 100 1" X 1"	S	30	7.9	1.8	1.0	1.5	2.0
	M	35	9.2	2.1			
FTMS - 150 1½" X 1½"	S	60	15.8	3.6	2.0	3.0	5.0
	M	75	19.8	4.5	1.5	2.0	3.0
FTMS - 200 2" X 2"	S	100	26.4	6.0	3.0	5.0	7.5
	M	125	33.0	7.5	2.0	3.0	5.0
FTMS - 250 2½" X 2½"	S	150	39.6	9.0	5.0	7.5	10.0
	M	200	52.8	12.0	3.0	5.0	7.5
FTMS - 300 3" X 3"	S	250	66.0	15.0	10.0	12.5	15.0
	M	330	87.1	19.8	7.5	10.0	12.5
FTMS - 400 4" X 4"	S	415	109.6	24.9	15.0	20.0	25.0
	M	500	132.0	30.0	12.5	15.0	20.0

## SALIENT FEATURES

- Working Pressure upto 10Bar.
- Size from ½" to 4" to handle flow from 15LPM to 500LPM.
- Can handle maximum viscosity 25000CST.
- Designed to handle fluid at temperature 200°C.
- Self-lubricating PTFE coated DU bush bearing type pumps for smooth performance in dry condition.
- The four piece construction in the pump makes it easy to clean & maintain and are designed to handle thinner & thicker or even corrosive liquid having lesser lubricating value.
- The pump is provided with double helical nitrided Gear to give longer life and also it helps to prevent axial and side thrust.
- Sealing options available – Gland Packing / Single Mechanical Seal / Oil Seal.
- The pump is provided with pressure relief valve.
- The pump with jacketing construction is provided to facilitate heating of the pump by steam or thermic fluid.
- The pumps direction can be changed clockwise to anticlockwise without opening the pump by changing the position of the relief valve.

## LIQUIDS CAN HANDLE

- For firefighting – foam pressuring application.
- For machine tools – high pressure coolant transfer.
- Heavy viscous liquid transfer application like Molasses, Magma, Soap Solution, Paints, Varnish, Vegetable Oil, Painting Ink, Spent Wash & Cosmetic Products.
- Non-Corrosive Viscous Chemicals.

## APPLICATION INDUSTRIES

- Oil & Gas Industry
- Steel Plant
- Paint, Varnish & Ink Industry
- Sugar Industry
- Pharma Industry
- Chemical Industry

## ACCESSORIES

- Stand and Base Plate
- Product Connecting Flanges
- Motor and Gear Reducers
- Variable Frequency Drives
- Electric Motor Stator
- Couplings

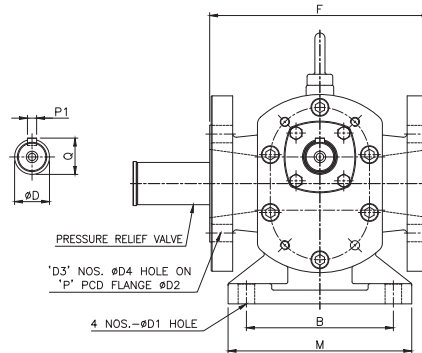
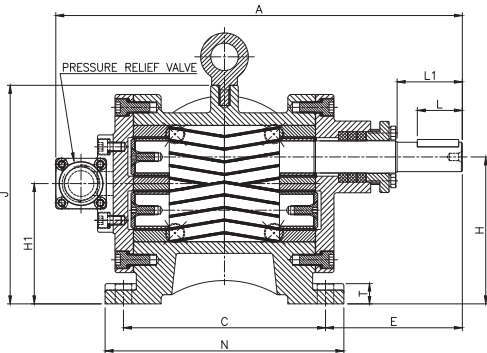

## MATERIAL OF CONSTRUCTION

Part	Material
Pump Body	CF8M (SS-316)
Front Cover	CF8M (SS-316)
Back Cover	CF8M (SS-316)
Gland Cover	CF8M (SS-316)
Rotor & Stator Shaft	AISI (SS-316)
Gear	AISI (SS-316)
Bushes	Teflon Coated DU
Wear Plate	Bronze
R.V. Housing	AISI (SS-316)
R.V. Piston	AISI (SS-316)
R.V. AD. Screw	AISI (SS-316)
Sealing	Gland Packing/Mechanical Seal

## DIMENSIONAL DRAWING DETAILS

PUMP MODEL	DIMENSIONS																					"WEIGHT OF PUMP (IN KG)"
	OVERALL			MOUNTING								FLANGE				SHAFT						
	A	F	J	B	C	E	H	H1	ØD1	M	N	T	ØD2	D3	ØD4	P	ØD	L	L1	P1	Q	
FTMS - 050	221	145	123	80	100	75	80	67.5	10	108	128	13	89	4	16	60.3	11.85	26	34	4	13.35	8.0
FTMS - 100	253.5	160	140	90	110	89	90	74.25	10	124	144	15	108	4	16	79.4	15	29	37	5	17	12.0
FTMS - 150	298	180	160	105	130	103	100	80	10	138	164	16	127	4	16	98.4	21	34	44	6	23.5	19.0
FTMS - 200	332	200	174	110	150	117	112	89.5	12	145	185	15	152	4	19	120.7	24	39	54	8	27	25.0
FTMS - 250	369	220	202	130	160	136	132	106	15	165	200	15	178	4	19	139.7	27	44	57	8	30	36.0
FTMS - 300	443	240	238	160	220	149	160	131	18	200	260	22	191	4	19	152.4	32	49	71	10	35	55.0
FTMS - 400	514	280	275	180	270	164	180	145.5	18	220	318	26	229	8	19	190.5	37	54	64	10	40	88.0

\* All dimensions are in millimeters. Unless otherwise stated, specifications are subject to change without prior notice as improvements are made from time to time.

Mfgd. by :

An ISO 9001:2015 Certified Company



**Fluid Tech Systems**  
Ahmedabad - 382 430, (Guj.) INDIA  
E-mail : info@rotofluidpumps.com, mail@rotofluidpumps.com  
Website : www.rotofluidpumps.com

Distributor :